

10 9 8 7 6 5 4 3 2 1

REV	DATE	DESCRIPTION
A	12/02	REDRAWN ON CAD
B	04/03	UPDATED TOLERANCES

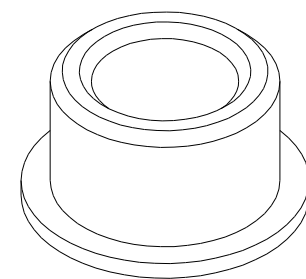

ISOMETRIC VIEW  
SCALE 1:1

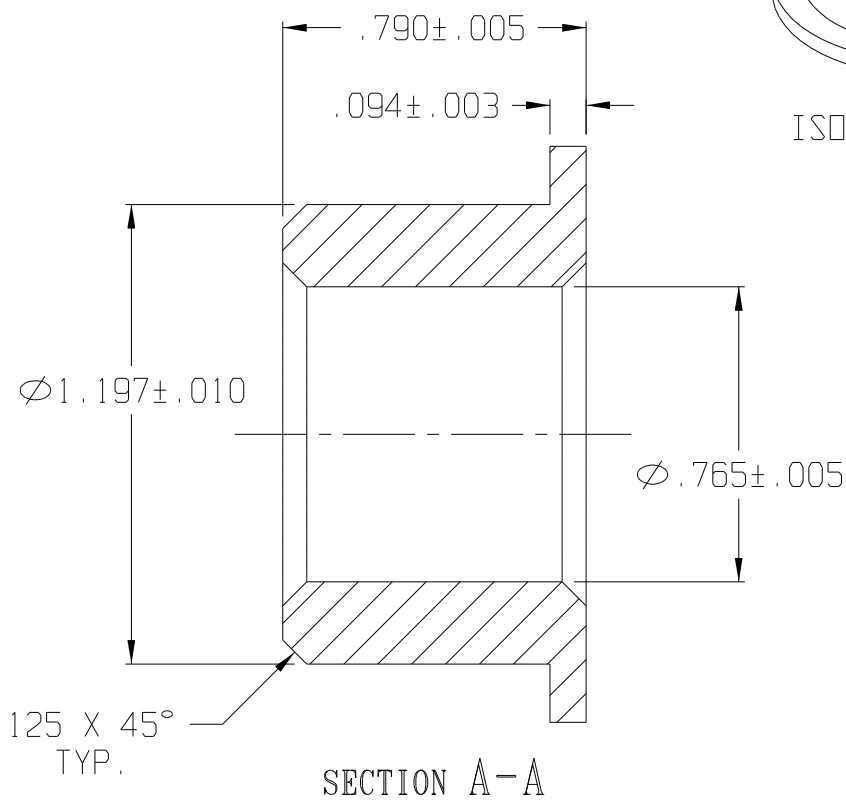
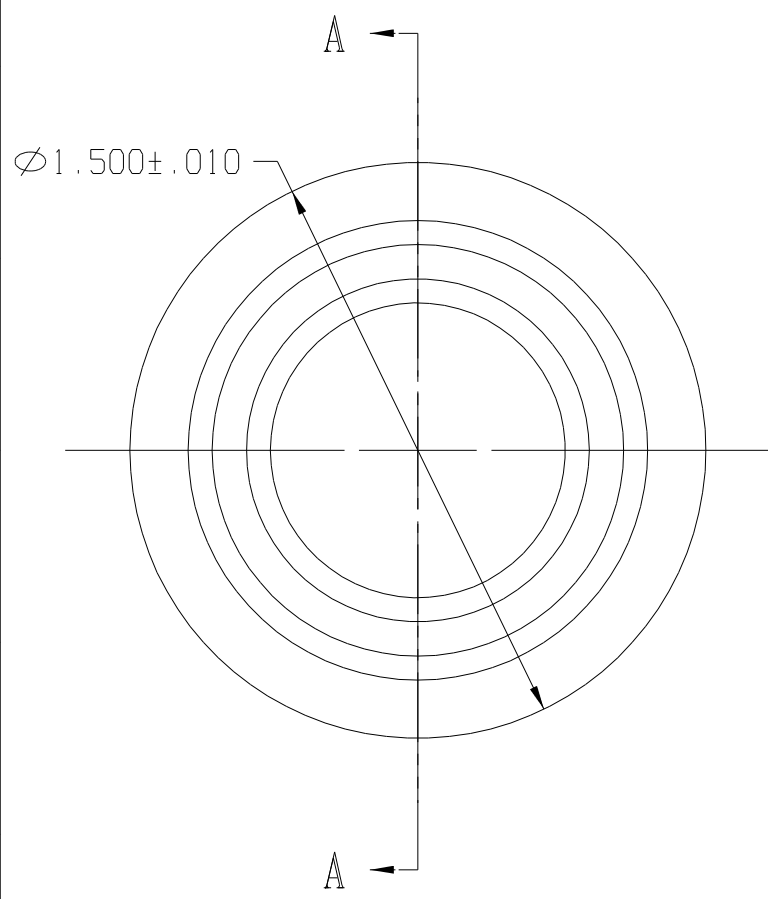

F:CADKEY/AUCILLA BEARING/PART PRINTS/API 2232\_B

THIS DOCUMENT CONTAINS PROPRIETARY DESIGNS, SPECIFICATIONS, DATA, INFORMATION AND TECHNICAL MATERIAL THAT ARE THE SOLE PROPERTY OF AUCILLA, INC. THIS INFORMATION IS TO BE HELD AND TREATED BY ITS RECIPIENT ON A CONFIDENTIAL BASIS, AND IS NOT TO BE SHOWN OR DISCLOSED TO THIRD PARTIES WITHOUT THE WRITTEN CONSENT OF AUCILLA INC. THIS DATA DOES NOT CONVEY MANUFACTURING RIGHTS TO ANY ITEM SHOWN.



STANDARD TOLERANCES APPLY UNLESS OTHERWISE NOTED	
LINEAR INCH	ANGULAR
4 PLACE $\pm$ -----	4 PLACE \ -----
3 PLACE $\pm$ .010	3 PLACE \ -----
2 PLACE $\pm$ -----	2 PLACE \ -----
1 PLACE $\pm$ -----	1 PLACE \ -----
WHOLE $\pm$ -----	WHOLE \ -----

DESCRIPTION FLANGED BEARING, SOLID			
PART NO.	LS-111-2232	API NO.	2232
MATERIAL	Stonyl TW341 Nat	DRAWN BY:	Dittrich
SCALE:	2:1	REV.	B
DATE:	Dec. 2002		

10 9 8 7 6 5 4 3 2 1