

10	9	8	7	6	5	4	3	2	1
REV	DATE	DESCRIPTION							
A	10/03	UPDATED TOLERANCES							

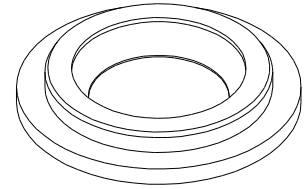

ISOMETRIC VIEW  
SCALE 1:1

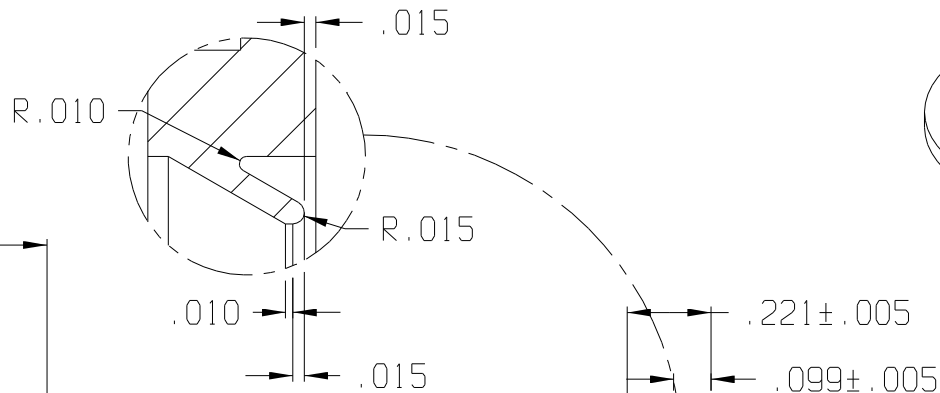
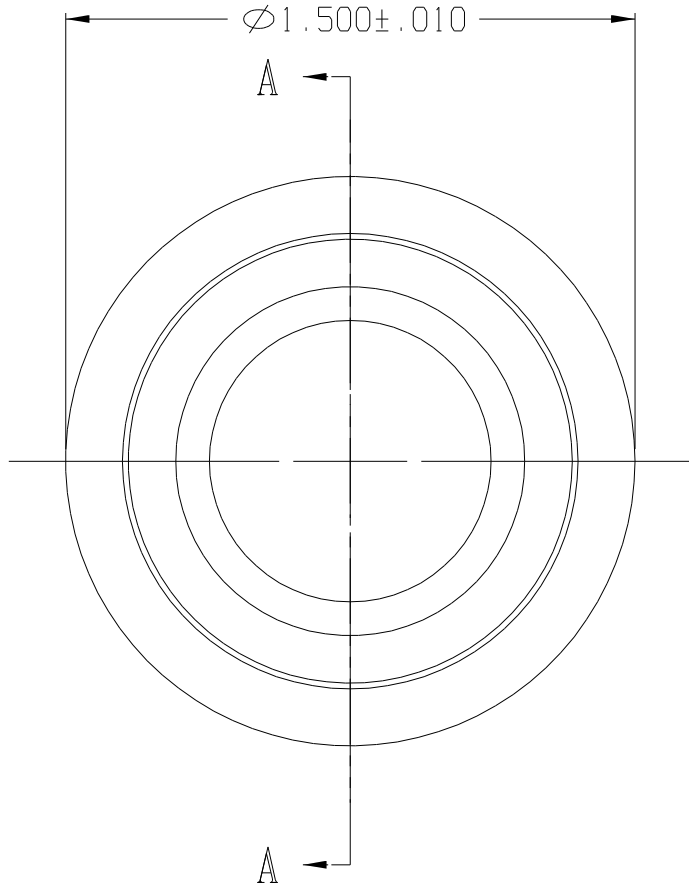
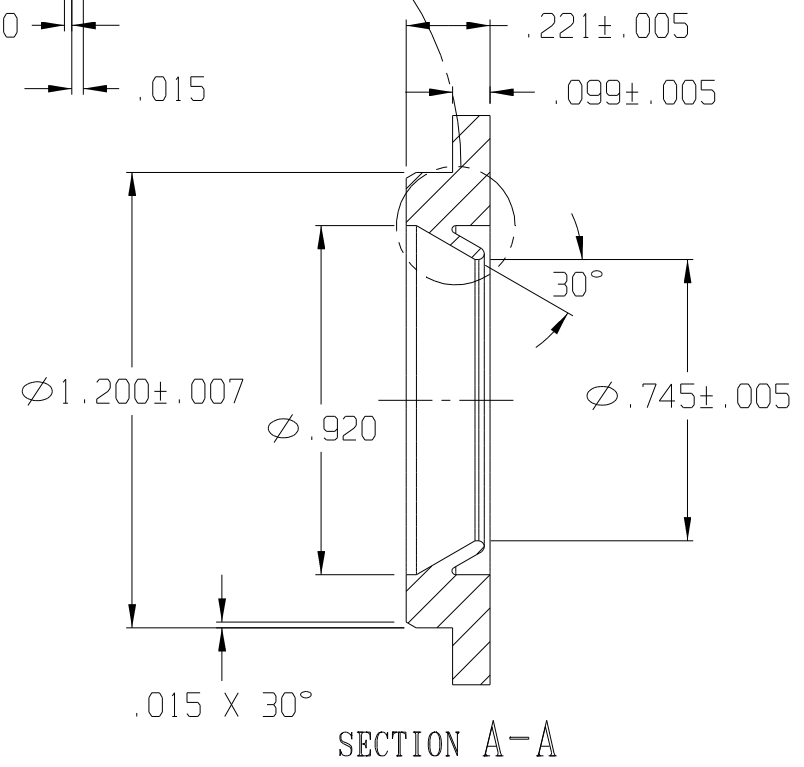

SECTION A-A

F:CADKEY/AUCILLA BEARING/PART PRINTS/API 2595\_A

THIS DOCUMENT CONTAINS PROPRIETARY DESIGNS, SPECIFICATIONS, DATA, INFORMATION AND TECHNICAL MATERIAL THAT ARE THE SOLE PROPERTY OF AUCILLA, INC. THIS INFORMATION IS TO BE HELD AND TREATED BY ITS RECIPIENT ON A CONFIDENTIAL BASIS, AND IS NOT TO BE SHOWN OR DISCLOSED TO THIRD PARTIES WITHOUT THE WRITTEN CONSENT OF AUCILLA INC. THIS DATA DOES NOT CONVEY MANUFACTURING RIGHTS TO ANY ITEM SHOWN.



STANDARD TOLERANCES APPLY UNLESS OTHERWISE NOTED			
LINEAR INCH		ANGULAR	
4 PLACE	± .0000	4 PLACE	∖ .0000
3 PLACE	± .0010	3 PLACE	∖ .0000
2 PLACE	± .0005	2 PLACE	∖ .0000
1 PLACE	± .0001	1 PLACE	∖ .0000
WHOLE	± .0000	WHOLE	∖ .0000

DESCRIPTION GREASE SEAL			
PART NO.	2595	API NO.	2595
MATERIAL:	TP100 Not.	DRAWN BY:	Dittrich
SCALE:	2:1	DATE:	March 2003
REV.	A		